

Leeb VT



FLEXIBILITY AND PRECISION



# Leeb VT

Innovative slide frame and drives for optimum performance

- Extremely comfortable chassis ComfortDrive: hydropneumatic individual wheel suspension with active level control
- Variable track adjustment from 1.80 m to 2.40 m
- High continuous ground clearance up to 1.30 m in field mode
- Practical control terminals and an ergonomic joystick for an intuitive operation, perfectly adapted to the application requirements
- Continuous inside cleaning CCS Pro with electrical valves and external control terminal, spraying and cleaning functions can be controlled in the cabin



The objective when developing the HORSCH Leeb VT was to achieve more with fewer machines in a shorter time – due to this strategy, farms today succeed in operating profitably and remaining competitive. As a manufacturer of crop care technology, our aim is to support farmers and entrepreneurs with efficient and precise technology.

Our R & D engineers do their best to provide appropriate solutions for the specific requirements on application technology in the crop care sector and to design a powerful and flexible machine for a wide range of applications. The result is a new generation of the Leeb VT, combining driving comfort, performance, and maximum application efficiency. The Leeb VT leaves nothing to be desired and offers more possibilities than ever before: variable track adjustment, more clearance, more driving comfort, greater climbing ability, more options with regard to the working width. In short: the Leeb VT offers an almost unlimited variability for highest demands on technology as well as on driving comfort.

Due to the possibility to customize the control terminal to the farmer's preferences and requirements in the cabin, operation in the familiar environment is easily possible. The joystick, developed especially for a self-propelled crop care sprayer, shows all necessary functions clearly and also allows the driver to freely assign the buttons to be able to adapt the machine even more individually. All these solutions help to provide the driver with a pleasant working environment, thereby increasing efficiency and performance. The well-known components that make a HORSCH Leeb sprayer unique remain the same. The powerful rotary pump with 1 000 l/min ensures highest suction rates and short filling times. Due to the active BoomControl control system, the liquid is then placed without drift and precisely on the target.



Comfort cabin for optimal working conditions

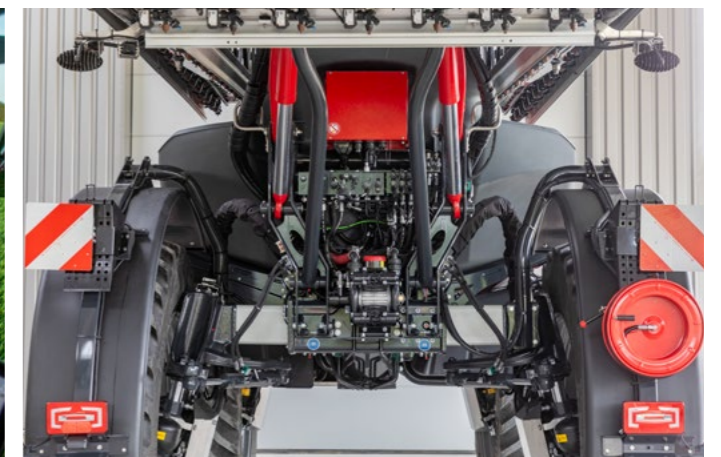

Slide axles that are positioned one after another and hydropneumatic suspension

# CONDITIONS OF USE



- Uncompromising driving comfort: due to the individual suspension of all four wheels on slide frames, a driving comfort comparable to that of a passenger car is achieved. Even during fast cornering in roundabouts or on the headlands, the Leeb VT remains stable due to the cross-linking of the axles.
- 50:50 weight distribution: due to the balanced weight distribution of 50% on the front axle and 50% on the rear axle in working position, compaction is actively prevented without affecting traction.
- Almost no limits: due to several available drives, there are almost no limits for the VT. With the standard drive

- OptiGear with a displacement of up to 190 cm<sup>3</sup> per axle, the Leeb VT achieves top performance in the field as well as on the road.
- With PowerGear, the drive has a capacity of up to 230 cm<sup>3</sup> and provides the customer with more power and performance reserves.
- Innovative innovations like PrecisionSpray, the HORSCH LEEB pulse width modulation, for an even more precise application.
- HorschConnect allows for a full control of the machine and the current status of the machine – an intelligent telemetry solution.



## Theodor Leeb

*Compact design and flexible track widths combined with the usual performance of a HORSCH Leeb self-propelled sprayer characterize our VT series.*

# CCS Pro

## ContinuousCleaningSystem Pro



ContinuousCleaningSystem Pro (CCS Pro)

In addition to the characteristics of the CCS system, for the CCS Pro version several cleaning programs can be started easily and comfortably at the push of a button in the cabin

1. Complete cleaning: rinses injector line – via the filter to the boom – completely with fresh water and then continues with the continuous inside cleaning (CCS) for mixture tank and boom.
2. Dilution: dilute the spraying mixture in the desired ratio with just a few simple steps
3. Intensive washing program: recommended for an extra thorough cleaning, e.g. when changing between crops.
4. Boom cleaning: automatic rinsing of the boom, e.g. if the work is interrupted for several hours
5. Background cleaning: intelligent, continuous inside cleaning that cleans the inside wall of the tank with fresh water while spraying. This prevents deposits on the tank wall.

The pressure control in the system is carried out via the pump speed. The pump only conveys the amount of liquid that is required for spraying plus the defined quantity for the agitator and thus used especially energy-saving. Fresh water as well as mixture tank are equipped with an electric level indicator for automatic washing programs and an automatic switchoff.

- Continuous inside cleaning with several cleaning and rinsing programs, can be operated comfortably in the cabin
- Pressure sensors for pump, agitator, inside cleaning and boom, suction and pressure side electrically controlled
- Operation with a large external terminal with all important induction functions
- Quick cleaning process of the sprayer without having to get off
- Relaxed filling process due to the standard automatic two filling limits
- Automatic filling level dependent agitator performance and switch-off



External control terminal CCS Pro

# Water cycle – CCS Pro – Leeb VT

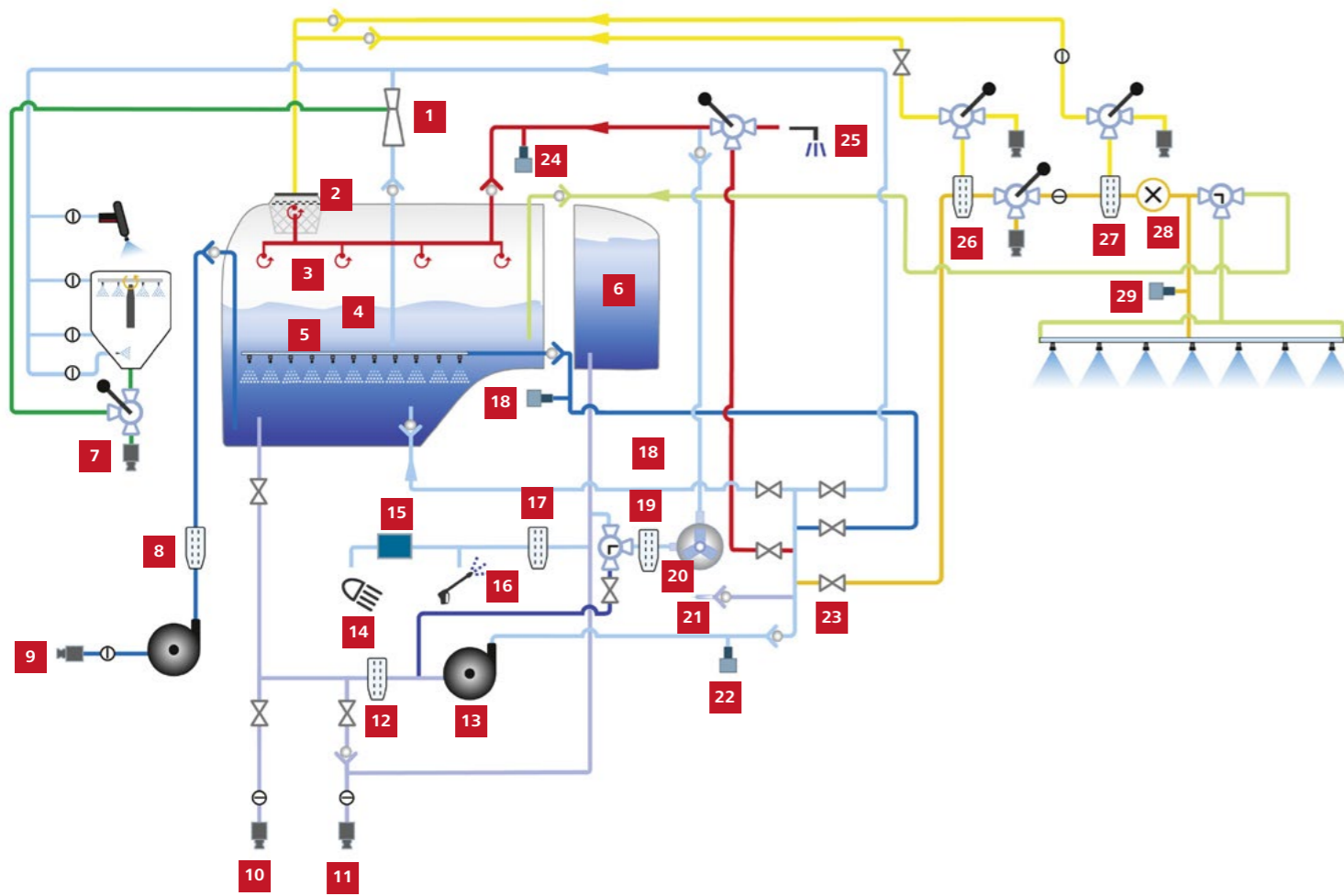

- |                                |                                 |                                |
|--------------------------------|---------------------------------|--------------------------------|
| <b>1</b> Injector              | <b>11</b> Filling fresh water   | <b>21</b> Exhaust function     |
| <b>2</b> Dome sieve            | <b>12</b> Suction filter        | <b>22</b> Pressure sensor      |
| <b>3</b> Internal cleaning     | <b>13</b> Rotary pump           | <b>23</b> Electric switch unit |
| <b>4</b> Spraying mixture tank | <b>14</b> NightLight cleaning   | <b>24</b> Pressure sensor      |
| <b>5</b> Agitator              | <b>15</b> Electric pump         | <b>25</b> Outside cleaning     |
| <b>6</b> Fresh water tank      | <b>16</b> High-pressure cleaner | <b>26</b> 1. pressure filter   |
| <b>7</b> Filling sluice        | <b>17</b> Fresh water filter    | <b>27</b> 2. pressure filter   |
| <b>8</b> Filter                | <b>18</b> Pressure sensors      | <b>28</b> Flow meter           |
| <b>9</b> Direct filling        | <b>19</b> Filter                | <b>29</b> Pressure sensor      |
| <b>10</b> Suction filling      | <b>20</b> Piston diaphragm pump |                                |

# Distribution system and induction hopper

No hose is the best hose

The sophisticated distribution system ensures an optimum supply of boom, intensive agitator, inside tank cleaning and induction hopper. Only one hose and one return flow hose are required for the circulation of the spraying mixture across the entire boom width, thus minimising deposits and facilitating cleaning.

The swivelling induction hopper with a gas pressure absorber and a durable stainless steel labelling is equipped with an efficient injector filling. Upper and lower rinsing nozzles create a whirl-like circulation for quickly flushing-in liquids and are also suitable for granulate. Moreover, the induction hopper is equipped with an additional canister cleaning nozzle as well as a symbol bar with coloured control levers.

As an option, the stainless steel induction hopper pot is available with a capacity of 52 l and the additional shock nozzle.



52 l stainless steel induction hopper incl. additional shock nozzle

- Permanent circulation of the active ingredient solution
- Large tube and line cross sections for optimum circulation, no deposits and blockages
- Permanent spraying fluid at the nozzle, exact switching on and off
- Powerful induction hopper with convincing functions
- Safe cleaning: displacement of the mixture with fresh water

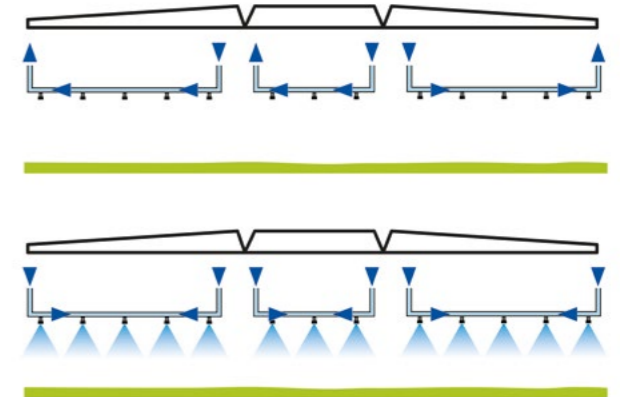

When the pump is running, a mixture circulates continuously in the boom (top) so that it is immediately available at the nozzle when spraying (bottom).

# Boom options

Precise technology – sophisticated to the last detail

For the boom, we rely on the well-proven system consisting of parallelogram suspension and the widely proven boom control system BoomControl in working widths from 24 to 48 m which guarantees an extremely stable boom position even in very uneven terrain and at high operational speeds. The patented suspension with active control of the middle section prevents dipping while cornering and on the

headlands. The wings of the folding boom are equipped with an overload protection to guarantee safe operation at any time. The weight-optimised design made of durable aluminium profiles protects nozzles, nozzle bodies and spray lines against damage. Different folding options allow for individual solutions for every farm.

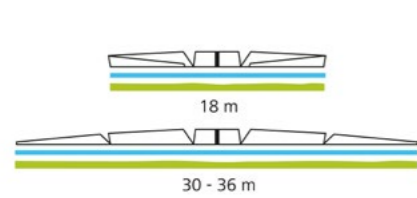

BoomControl – 5-part with reduced working width 18 m

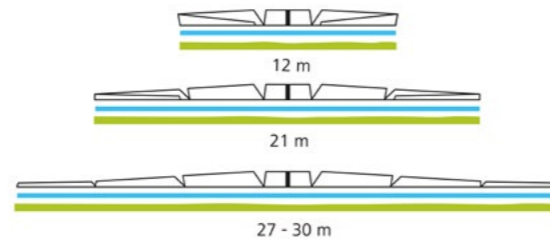

BoomControl – 7-part with reduced working width 12 m and 21 m

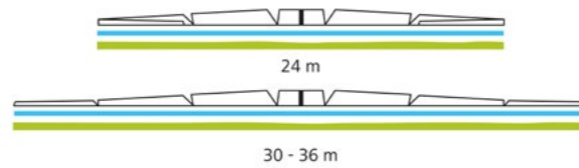

BoomControl – 7-part with reduced working width 24 m

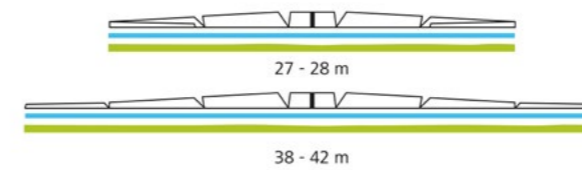

BoomControl – 7-part with reduced working width 27-28 m

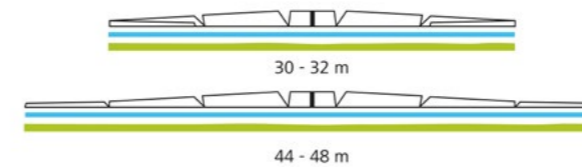

BoomControl – 7-part boom with reduced working width 30 m

- Parallelogram suspension with BoomControl for smooth boom operation in all situations
- Basic boom versions in working widths ranging from 24 to 48 m
- Stable aluminium profile as wind and nozzle protection
- Overload protection and damping of the wings: collision protection
- Overload protection of the outside wings towards the rear, damping of the inside wings to the front and rear

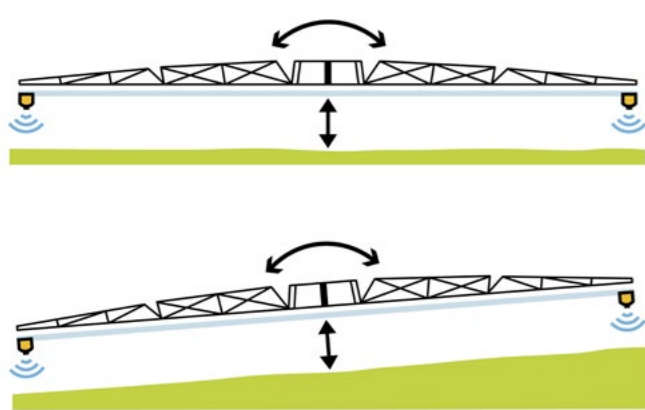

BoomControl – active adaption of the boom to the terrain due to two sensors

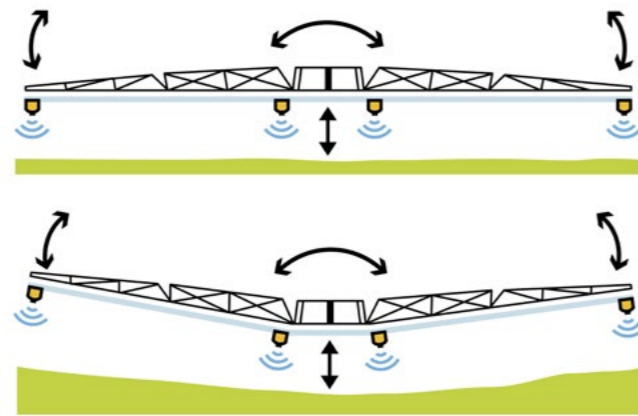

BoomControl Pro – active adaption of the boom to the terrain by means of four sensors

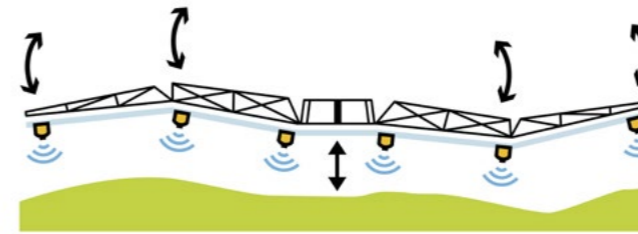

BoomControl Pro Plus

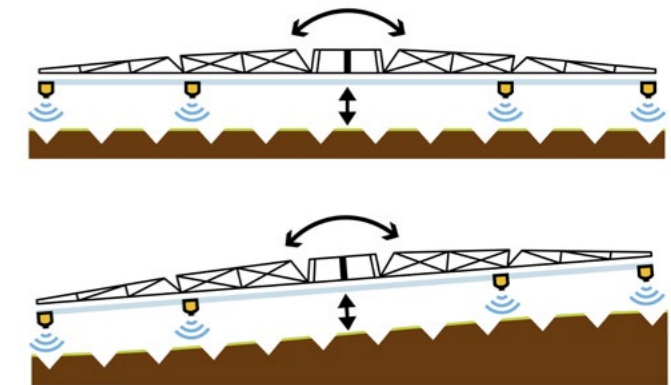

BoomControl/BoomControl Pro extension – extension of the field of vision is ideal for ridge and row crops

## BoomControl

Active boom control system  
BoomControl

- Maintenance of the exact, lowest possible working height due to active boom control system
- Boom control system with a target area spacing of less than 40 cm ensures minimal drift
- Active adaption of the boom to the terrain by means of two sensors

## BoomControl Pro

Active boom control system  
BoomControl Pro

- Independent angling of the boom arms and rotation of the middle section to adapt to the terrain
- Active adjustment of the boom to the terrain with 4 sensors
- Maintenance of the exact, lowest possible working height due to automatic boom control system
- Boom control system with a target area spacing of less than 40 cm ensures minimal drift
- Boom is completely decoupled from the vehicle

## BoomControl Pro Plus

Active boom control system  
BoomControl Pro Plus

- Independent angling of the boom arms and rotation of the middle section to adapt to the terrain
- Angling (lifting and lowering) of the two outside wings
- Active adjustment of the boom to the terrain by via sensors
- Maintenance of the exact, lowest possible working height due to automatic boom control system
- Boom control system with a target area spacing of less than 40 cm ensures minimal drift

## Extension

BoomControl/BoomControl Pro

- Active adaption of the boom to the terrain by means of two additional sensors
- To extend the field of vision
- Ideal for ridge and row crops or for reduced working widths

# PrecisionSpray

Pulse Width Modulation – State-of-the-Art Application Technology



PrecisionSpray is a pulse nozzle system that triggers the nozzles in a pulsating way at a frequency of 20 Hertz. This allows for adjusting the application steplessly via the Duty Cycle – with constant pressure and drop size at variable speed and while maintaining the spraying characteristics. This allows for using larger nozzles which are less susceptible to clogging, and the number of necessary nozzle sizes are minimised. For optimal longitudinal and transverse distri-

bution, the nozzles are switched alternately. The system is fully integrated into ISOBUS and the HORSCH sprayer software: with curve compensation and the use of application maps, over- and underdosage can be avoided actively. Active resistance management and even populations with minimal mixture consumption make the nozzle a tool for Precision Farming.

- Stepless adjustment of the flow rate with constant pressure and drop size
- Constant drop spectrum when using a nozzle
- Fewer different nozzle sizes required
- Adjustment of the application rate without altering spraying characteristics
- Curve compensation and VariableRate per section
- Generally larger nozzle bodies that are less prone to clogging

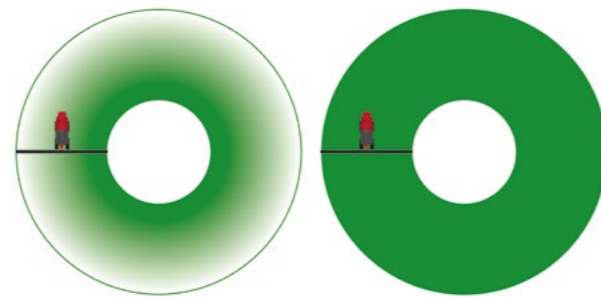

Avoid over and under applying due to curve compensation

# Pneumatic nozzle and section control

Performance due to diversity

Due to the pneumatic nozzle control and the pneumatic section control, it is possible to precisely switch off nozzles and sections with compressed air. Nozzle spacings of 25 cm and 50 cm are available.

Individual and intelligent application technologies allow for an optimum penetration and wetting of the population. Variable nozzle body combinations (pneumatically switchable) can also be used. All nozzles are controlled individually

and are pneumatically combined in sections. This also facilitates maintenance and the easy detection and repair of errors and blockings at the nozzles. As standard, all nozzle body configurations are equipped with nozzle holders for edge nozzles. Comprehensive tests in our wind tunnel show considerable advantages with regard to the drift behaviour depending on the target height.

- Individually controlled nozzles, combined pneumatically in sections
- 6 to 42 possible sections (standard sections or individual configuration options)
- Excellent penetration and wetting of the population
- Optimum target area spacing with a nozzle spacing of 25 cm
- Allows for individual and intelligent application technologies

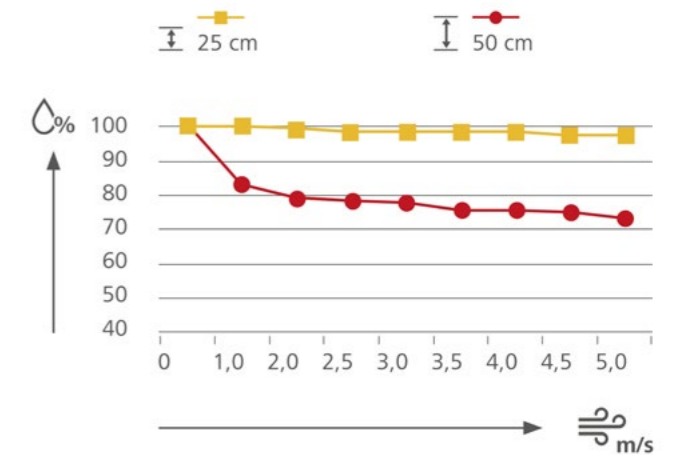

Drift comparison: wetting (in %) depending on the wind force (m/s) at a target area spacing of 25 and 50 cm



Band spraying is also no problem for a 25 cm spacing



25 cm nozzle layout: more nozzles, more options, e.g., 3D application



Pneumatic nozzle and section control

# AutoSelect

Various combination options with up to 16 storable, different nozzle profiles – to be switched on or off from the cabin. Without interruption, the optimal pressure range that can be configured via the terminal and the corresponding nozzle size are adjusted automatically. Automatic adjustment of the boom height based on the defined nozzle profiles and automatic switching between the nozzle levels. This is based on the nozzle spacings that are stored in the nozzle profiles. Thus, with more nozzles, the farmer has more options.

Fully automatic AutoSelect control system: control of nozzle size or combination while simultaneously adjusting the application rate and the operational speed. High comfort and safety for optimal management of the spacing requirements along waters and terrestrial structures.

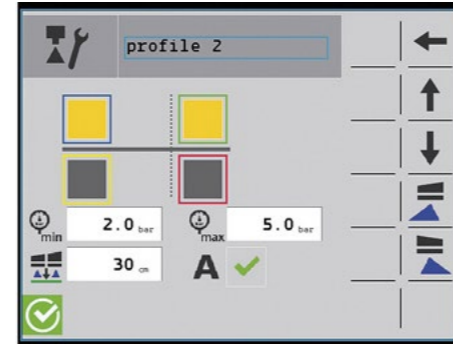

AutoSelect menu in the terminal

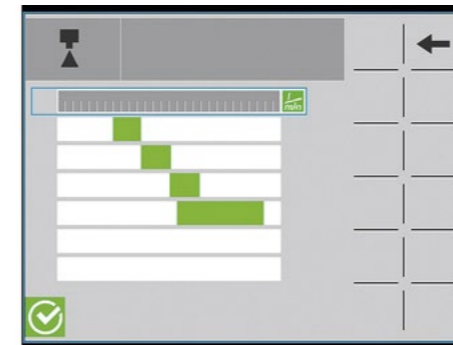

AutoSelect nozzle overlap

- Control of nozzle size and combination while simultaneously adjusting the application rate and the operational speed
- Possibility to adjust not only the pressure range but also the target area spacing to comply with spacing requirements
- Optimal management of spacing requirements along waters and terrestrial structures
- Automatic adjustment of boom height based on the defined nozzle profiles
- Can be switched on and off comfortably from the cabin

# AutoSelect Pro

AutoSelect Pro takes HORSCH's own nozzle control system to the next level. The separate activation of curve compensation allows for combining profiles, thus specifically increasing the application rates on the outer sides of the curves when cornering. At the same time, the application rate is reduced by switching to a smaller nozzle size on the inside of the curve.

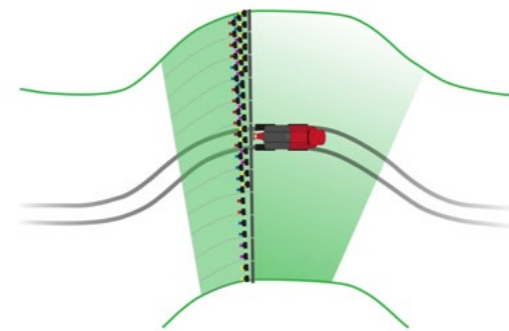

AutoSelect Pro: curve compensation

- All functions of AutoSelect
- Additionally: activation for curve compensation for pneumatic nozzle control
- Quantity adjustment when cornering by combining the profiles
- Reduction of over- and underdosage, decrease of resistances

# NightLight

Optimal spraying control at night



Innovative and powerful LED lights ensure an optimum illumination with their heavily focused light which penetrates all spraying cones. Thus, the lighting system guarantees more safety and efficiency while spraying around the clock. A strong LED spotlight is installed per boom side to ensure optimum spraying control at twilight and at night as well as an overview of the nozzle function – also in section mode. The automatic light function deactivates the headlights on the headlands to prevent that for example passers-by are blinded.

Optionally, NightLight can be combined with an automatic washing system that automatically cleans the lights and prevents dust from settling on the lights. Moreover, LED light strip at the induction centre as well as a LED apron lighting are available.

- Innovative LED technology ensures optimum illumination
- Strongly focused light penetrates all spraying cones.
- Optimal spraying control also at dusk and at night
- 100% control of the nozzle function – even with section control
- More safety and efficiency for spraying operations around the clock
- Optional: NightLight with cleaning
- Optional: light bars at the induction centre and boom apron lighting



NightLight incl. cleaning

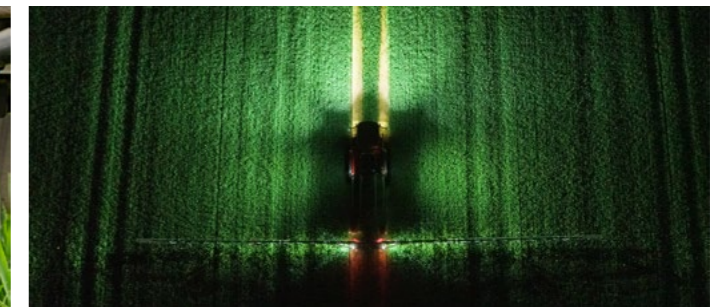

NightLight nozzle cone illumination

# Ergonomic operating concept

Innovative operation with the highest requirements on the workplace

The cab of the HORSCH self-propelled sprayer offers numerous comfort features as well as an innovative and well-thought-out operating concept.

Machine, driving, and spraying data can be displayed and individually configured via the bright and high-resolution 12" A-column display. The camera views and the programming of the joystick are also displayed. The display is operated via buttons in the armrest in a comfortable seating position. The in-house developed control lever offers 30 freely assignable buttons on different levels and an ergonomic cork grip shell. With the new softkey „Sprayer Ready,“ circulation, agitator, all-wheel steering, and BoomControl are activated at the push of only one button.

The ergonomic steps fold in fully automatically as soon as the vehicle moves, and quickly fold out again if the operator stops the vehicle. This ensures that the ladder is always raised while spraying and crop damage is prevented.

The glazed cabin offers an excellent circumferential visibility and a lot of free moving space for long working days. A comfortable footrest helps to find a relaxed position behind the wheel at any time. The integrated DAB radio with Bluetooth function and hands-free system is conveniently operated via the armrest. An integrated mobile phone holder with inductive charging function is included. Numerous storage compartments, the actively cooled 30 l cool box, and the automatic climate control ensure comfort during long working days. For user protection, a Cat. IV cabin filtering is already prepared and fully integrated into the cabin. The operation of the air conditioning system and the control of the up to 18 LED working lights to monitor the work quality are integrated into the roof rail.

A pneumatic 4-point cabin suspension and a safety bar for the bumper are available as an option.

- Control lever with multi-configurable keys integrated in an ergonomic control armrest
- 12" display in the A-column with customisable main page, machine, driving, and spraying data
- Armrest with new machine functions, e.g. „Sprayer Ready“ – pump start + BoomControl

- Automatic air-conditioning/heating, operation of the air-conditioning function and lighting integrated in the roof strip
- Preparation for automatic Cat. IV cabin filtering (automatic control, fully integrated into cabin roof and roof ledge)



Comfortable and spacious cabin with joystick, mobile phone holder, and cup holder

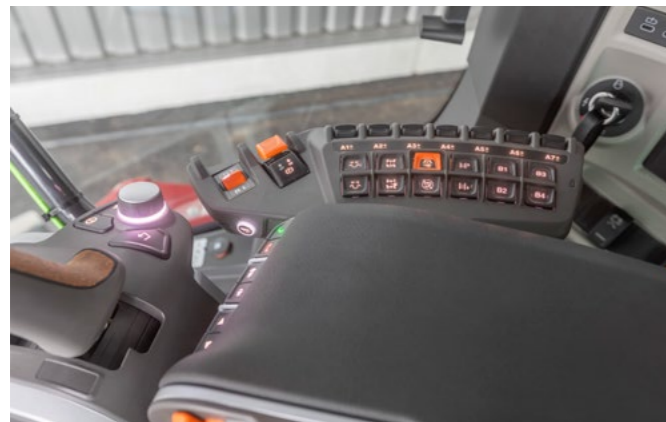

Comfortable operation of the functions compactly integrated into the armrest



Ergonomic control lever with multiply assignable buttons



Safe operation of the A-column display: rotary/push functions



Standard 12" A-column display with freely assignable display



Cabin with large glass surfaces for optimum circumferential visibility

# Cabin Pro

Optimal circumferential visibility and utmost comfort

In addition to the standard equipment, the Pro line offers a swivelling and air-suspended comfort leather seat with heating and ventilation as well as a passenger seat with leather padding. A lumbar support to relieve the spine and a headrest are integrated into the high backrest of the driver's seat, there is a foldable armrest on the left side. The damping and the longitudinal suspension of the premium seat can be adjusted in many ways. A triple cup holder is mounted for long workdays. With the integrated sun protection blinds at the front, rear and side windows, the light incidence and thus the heat development in the cabin can be regulated on sunny and hot days. In addition, there is a floor mat made of velour and a terminal mounting rail.



Comfort leather seat for fatigue-free working

# Cabin Basic

Front cabin with optimum visibility and circumferential view

The Basic equipment options offers the driver a length- and height-adjustable driver's seat covered with durable fabric and a passenger seat also covered with fabric. The spring-loaded and comfortably cushioned driver's seat has a backrest with an integrated lumbar support to relieve the spine and is equipped with an armrest on the left side. A double cup holder is integrated for long workdays. Sun protection blinds are mounted on the front and rear windows.

- Fabric seat with various adjustment options
- Double cup holder made of plastic for long workdays
- Sun protection blinds on front and rear windows

- Swivelling comfort seat with premium leather cover
- Seat heating and ventilation
- Triple cup holder for long workdays
- Sun protection blinds on front, rear and side window
- Additionally, there is a foot mat and a terminal mounting rail.



Cab Pro with comfort leather seat and leather passenger seat



Velours floor mat



Large cup holder



Cabin Basic with comfortable entry



Practical cup holder

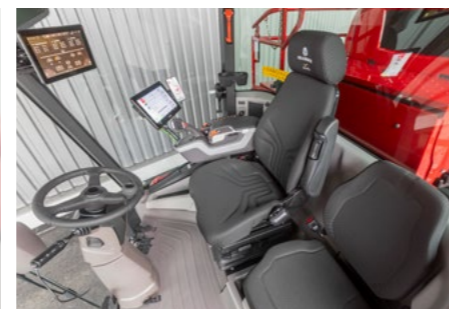

Comfortable passenger seat with fabric cover



Standard footrest



Storage facility under the driver seat with optional safety package



Spacious cooling compartment as standard

# Wheel drive OptiGear

## Efficient all-wheel drive

The OptiGear drive is equipped with standard all-wheel drive and an anti-slip control ensuring cross-country mobility with efficient utilization of the engine power. The drive system that has been specifically developed for the compact engine-power class with spraying tanks with a capacity of 5 000 l and 6 000 l is particularly fuel-efficient when combined with smaller engines. The optimized efficiency factor with larger wheel motors on the rear axle and the associated higher driving power distributes the drive torques powerfully and efficiently in the speed range of 0 – 50 km/h.

- Efficient all-wheel drive for the compact engine-power class
- Degree of efficiency in the main working range has been specially optimised for the use in the crop care sector
- Selective traction control for every wheel
- Stepless drive from 0 - 50 km/h
- Up to 170 ccm displacement of the wheel motors

# Wheel drive PowerGear

## Powerful all-wheel drive for optimal performance

The drive PowerGear allows for optimum performance in the field and also on the road. Equipped with a standard anti-slip control and all-wheel drive, the vehicle operates effortlessly in any terrain. The efficiency factor that has specifically been optimized for the use in the crop care sector with larger wheel motors on the rear axle and the associated higher drive power distribute drive torques powerfully and efficiently in the speed range of 0 – 50 km/h. This drive is ideal in combination with the more powerful engines especially for machines with larger mixture tanks and large booms.

- Powerful all-wheel drive even in steep terrain and on slopes
- Degree of efficiency in the main working range has been specially optimised for the use in the crop care sector
- Selective traction control for every wheel
- Infinitely variable drive from 0 – 50 km/h
- Up to 230 ccm displacement of the wheel motors



# HillControl

## Active slope counter-steering

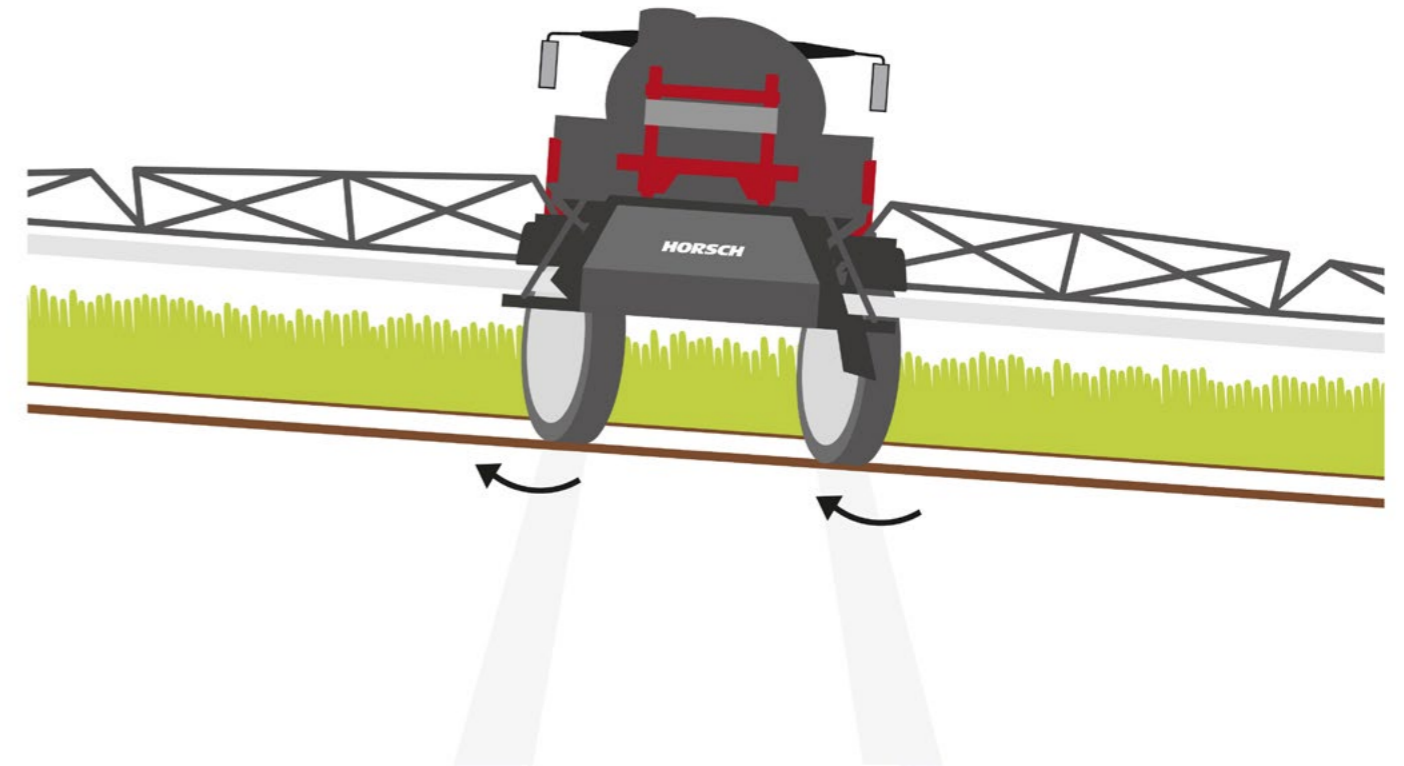

The active hillside counter-steering system HillControl compensates drift on side slopes and ensures a directionally stable following of the rear axle.

With the equipment HillControl, the rear axle of the self-propelled HORSCH Leeb crop care sprayer is controlled separately. This ensures safe trafficability on side slopes even in difficult conditions. The slipping of the machine is actively overridden, and the aggressiveness of the steering is adjusted infinitely.

Operation is extremely easy: activate HillControl and slightly adjust the steering to the conditions if necessary. The system stores the values until the next folding of the boom – in every driving direction across the entire field.

- Exact following in the tracks of the rear axle on side slopes
- Active hillside counter-steering, aggressiveness infinitely adjustable
- Easy operation, stored values are retrieved in each driving direction
- Safer trafficability on side slopes in demanding conditions

# PowerFill filling pump

Filling connection 3" with PowerFill filling pump



PowerFill filling pump with 1 000 l/min capacity – 3" Camlock filling connection in the front

With the PowerFill filling pump, the sprayer can be filled directly in the field with unfolded boom within a very short time. The pre-mixed mixture is pumped directly from a carrier vehicle into the tank with a pump capacity of up to 1 000 l/min, minimizing filling times.

- Reduces travel, idle and filling times
- Powerful pump with filling capacity up to 1 000 l/min
- Filling in the field with unfolded boom possible
- 3" filling connection for pre-mixed mixture



Filling in the field with unfolded boom

# Camera system

Cameras for monitoring the machine functions and the traffic area

Up to three high-resolution cameras can be mounted ex factory and transmit their footage to the 12" A-column display in the cabin. The display of the camera images can be adjusted at any time and adapted to the current requirements. The rear view camera is mounted on the middle section of the boom. The image is automatically zoomed to full screen size when going into reverse, showing the area behind the vehicle to facilitate manoeuvring. The lens with a view of the right front wheel helps the driver to keep the track precisely and to avoid damage to the population. The camera on the NightLight holder focuses on the nozzles behind the vehicle when the boom is folded out, allowing for keeping an eye on the function of the nozzles hidden behind the tank at all times.

- Integrated system with up to three cameras
- Rear view camera, camera with a view of the right front wheel, and camera lens for nozzle control
- Display of the various angles via the standard A-column terminal
- Wide angle and high light sensitivity for optimal visibility even in changing lighting conditions



Rear view camera for monitoring the area behind the vehicle



High-resolution, automatic display of the rearview camera in the A-column display



High-resolution, individual display of the track camera in the A-column display



Camera for nozzle monitoring on the NightLight holder

# INTELLIGENCE

## Terminal technology & steering system

### Tractor terminal 1060 or 1260 with steering system

The new terminal generation Trimble 1060 or 1260 allows for controlling the machine at top level. Due to the high resolution and the sophisticated user navigation, complex machine functions can be operated comfortably. The high efficiency and the large (working) memory allow for a smooth handling of large data quantities or application maps. Thus, it becomes the perfect all-rounder for machine operation.

Combined with a completely integrated steering system with receiver, the application of your self-propelled crop care sprayer becomes even more precise and the driving comfort is maintained even on long working days. The activation VariableRate completes the precision solutions when working with application maps.



High-resolution Trimble terminal with large screen

- Intuitive machine operation via the high-resolution Trimble Terminal 1060 or 1260
- Optional extension by a second terminal or optional control via different approved external terminals
- Fully integrated steering system with receiver Trimble Nav 900
- Additional activation of VariableRate for site-specific variable application by means of application maps



High-resolution Trimble terminal with large screen



Receiver Trimble Nav 900

## HorschConnect

Prepare today for tomorrow. Control various machine functions easily via the MobileControl app – your smartphone replaces the terminal! Gain full, transparent insight into work performance and work quality with HorschConnect Telematics.

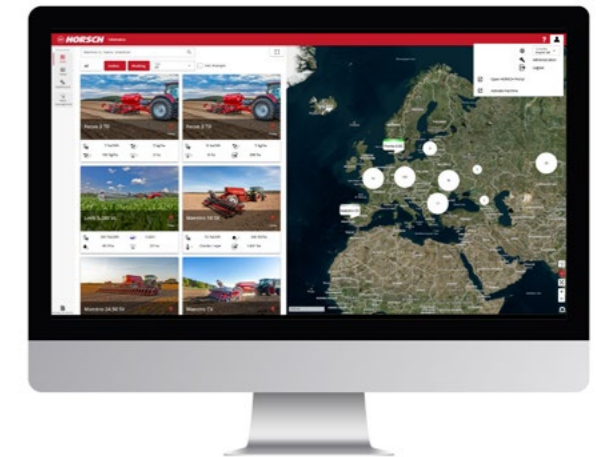

With HorschConnect telemetry solutions can be found in the sowing and plant protection sector – exactly where they make sense

- Digital solutions exactly where they make sense
- Straightforward out-of-the-box solution with already integrated SIM card, Wi-Fi modem and other interfaces
- HorschConnect Telematics: automated documentation of application rate, nozzle profile, nozzle status, pressure and target area spacing
- Targeted and proactive service due to remote viewing of error messages
- Control of machine functions via smartphone app MobileControl: e.g. carry out the nozzle test for individual sections



The MobileControl app allows for controlling individual machine functions – completely comfortably from the smartphone



Success factor transparency: position-specific data of all relevant information like error messages, application rate, nozzle status or target area spacing

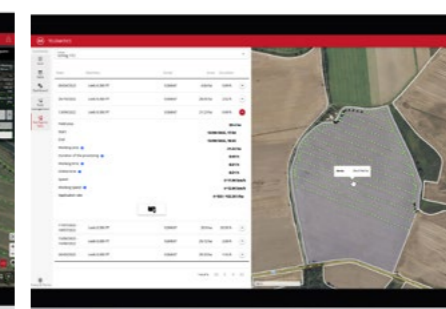

With the field boundaries import all data can be analysed over the season – even in a site-specific way



HorschConnect

# ADDITIONAL EQUIPMENT



52 l stainless steel induction hopper incl. additional shock nozzle



Hydraulically operated high-pressure cleaner



Pneumatic 4-point cabin suspension



Hose drum for outside cleaning



MotionControl to smooth the horizontal movements in the boom wings



Tank of the central lubrication unit

# TECHNICAL DATA

Leeb VT	5.230 VT	6.230 VT	5.300 VT	6.300 VT
Mixture tank nominal volume (l)	5000	6000	5000	6000
Water-cooled engine	FPT (Fiat Powertrain Technologies) N67	FPT (Fiat Powertrain Technologies) N67	FPT (Fiat Powertrain Technologies) N67	FPT (Fiat Powertrain Technologies) N67
Nominal power (for rpm) (kW/hp)	159 / 216 (2300)	159 / 216 (2300)	212 / 288 (2200)	212 / 288 (2200)
Maximum power (for rpm) (kW/hp)	165 / 224 (1900)	165 / 224 (1900)	230 / 313 (2000)	230 / 313 (2000)
Cylinder number/cooling	6 / water / turbo with charge air cooling	6 / water / turbo with charge air cooling	6 / water / turbo with charge air cooling	6 / water / turbo with charge air cooling
Cylinder capacity (cm <sup>3</sup> )	6700	6700	6700	6700
Max. torque (Nm/Speed)	942 / 1500	942 / 1500	1160 / 1500	1160 / 1500
Control	Electronic EMR	Electronic EMR	Electronic EMR	Electronic EMR
Tank capacity diesel/AdBlue (l)	Approx. 450/45	Approx. 450/45	Approx. 450/45	Approx. 450/45
Emission standard	Stage V	Stage V	Stage V	Stage V
Working widths (m)	24 - 48	24 - 48	24 - 48	24 - 48

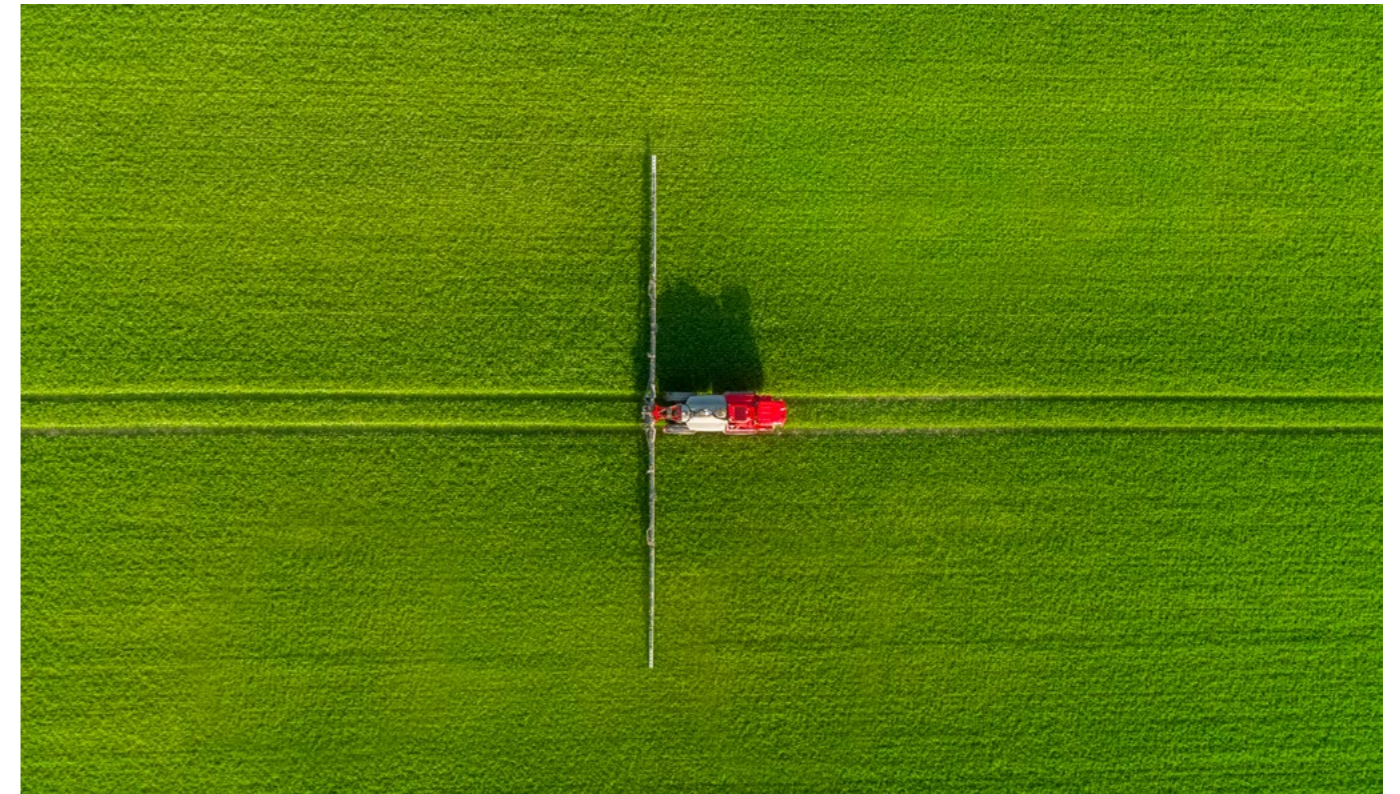



Your distributor

**HORSCH LEEB Application Systems GmbH**

Kleegartenstraße 54  
94405 Landau an der Isar  
Phone: +49 9951 6041-0  
Fax: +49 9951 6041-3092  
E-Mail: [info@horsch.com](mailto:info@horsch.com)

**[horsch.com](http://horsch.com)**

Paper: 120 g/qm Maxi Offset. The paper is certified according to the EU Ecolabel. This label is only granted for products and services whose environmental consequences are considerably lower than those of comparable products. For more details see [www.eu-ecolabel.de](http://www.eu-ecolabel.de). Printing ink: Printing ink QUICKFAST COFREE. Free from mineral oil and cobalt. Moreover, it is certified and recommended for printing according to the „Cradle-to-Cradle“ principle (quasi “from the origin back to the origin”) – an approach that deals with the spreading of continuous and consequent recycling management. For more details see [www.c2c-ev.de](http://www.c2c-ev.de).

All specifications and diagrams are approximate and not binding. Technical features and design are subject to change.

EN-60142364 (04/2025)